

## BIDET EVALUATION CHECKLIST

### Client Details

NAME	ADDRESS
PHONE	SUBURB
EMAIL	POSTAL CODE
CLIENT HEIGHT / WEIGHT	STATE
ADDITIONAL INFORMATION	

### Funding Body Details

DVA  
  NDIS  
  HOME CARE PACKAGE  
  OTHER

DVA FILE NUMBER	NDIS NUMBER
PLAN START DATE	PLAN FINISH DATE
DOB	FUNDING GROUP
EMAIL	

### Prescribing Therapist Details

NAME

PHONE

EMAIL

SUBURB

POST CODE      STATE

### Toilet Measurements

A	MM	A1	MM	B	MM
C	MM	D	MM	E	MM

WHERE IS THE WATER TAP LOCATED?    ON WALL    CISTERN

ACCESS TOILET SEAT BOLTS FROM:    UNDERNEATH    NO ACCESS

IS THERE ACCESS TO A POWERPOINT?    YES    NO

IS THERE TANK WATER IN USE?    YES\*    NO

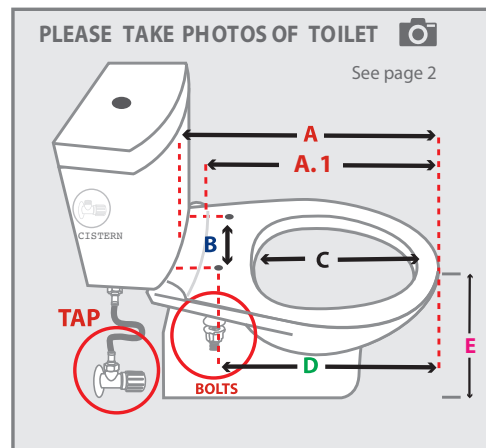

\*If using tank water please provide a photo of the pump.

### Order Form Please tick if required

RAISERS <input type="checkbox"/> 50MM <input type="checkbox"/> 80MM	ARMS <input type="checkbox"/> BARIATRIC <input type="checkbox"/> 3IN1 <input type="checkbox"/> ENDEAVOUR <input type="checkbox"/> LIBERTY ARMS	
<input type="checkbox"/> Hiline to recommend best fit	<input type="checkbox"/> Inteliclean 9000 (no RPZ required)	<input type="checkbox"/> Inteliclean Plus (no RPZ required)
<input type="checkbox"/> Coway	<input type="checkbox"/> BA08 ONLY Tamper Proof Holder	<input type="checkbox"/> BA08/BA13 ONLY 3 Way Foot or Hand Control

**PHOTO GUIDE - Below are examples of photos needed**

**Toilet Area**



**Above Toilet**

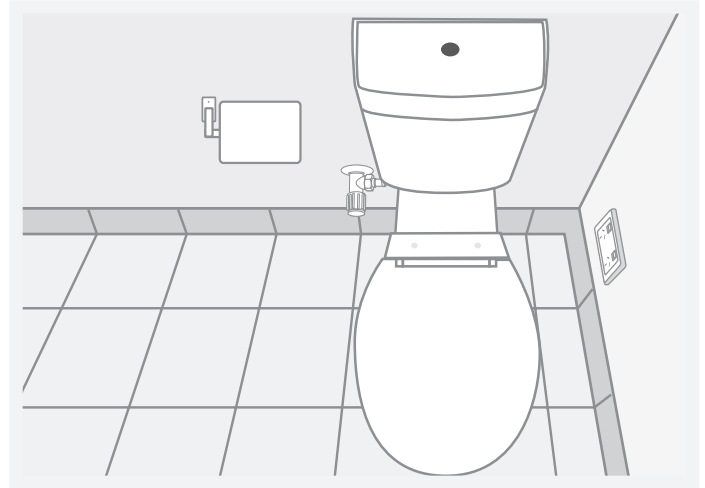

**Water Tap**

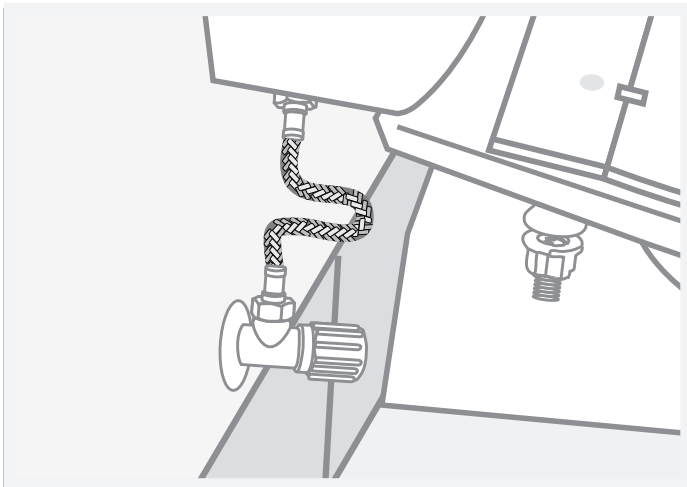

**Fitting Measurements Needed**

- (A) Front (centre) of cistern to front (centre) of bowl
- (B) Centre to centre of bolt holes
- (C) Back (inside centre) to front (inside centre) of bowl
- (D) Bolt holes to front of bowl
- (E) Measure from the floor to top of toilet bowl
- (A.1) If toilet bowl is not at all the way to the cistern (lip) measure from the lip to front (centre) of bowl.

**Safety Switch** (Please take a photo(s) of safety switch)

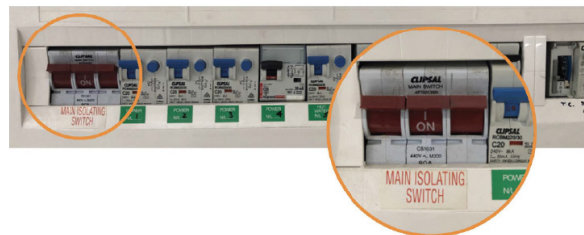

**INSTALLATION AND PLUMBING**

WARNING: THIS TOILET DOUCHE SEAT MUST BE INSTALLED WITH APPROPRIATE BACKFLOW PROTECTION CONFORMING TO THE NATIONAL CONSTRUCTION CODE - VOLUME THREE.